

OWNER'S CERTIFICATE:

WE, THE UNDERSIGNED, OWNERS OF A TRACT OF LAND HEREIN PLATTED AND FURTHER DESCRIBED IN THE FORGOING SURVEYORS CERTIFICATION HAVE CAUSED THE SAME TO BE SURVEYED AND SUBDIVIDED IN THE MANNER SHOWN ON THIS PLAT...

ALL EASEMENTS SHOWN ON THIS PLAT, UNLESS DESIGNATED FOR OTHER SPECIFIC PURPOSES, ARE HEREBY DEDICATED TO THE CITY OF PACIFIC, MISSOURI, SPRINT MISSOURI INC., UNION ELECTRIC COMPANY, DIBIA AMEREN MISSOURI, SOUTHWESTERN BELL TELEPHONE COMPANY...

SIDEWALK EASEMENTS ARE HEREBY GRANTED TO THE CITY OF PACIFIC, MISSOURI FOR PUBLIC USE FOREVER, MAINTENANCE OF THE SIDEWALKS SHALL BE THE RESPONSIBILITY OF THE CITY OF PACIFIC, MISSOURI.

THE FENCE EASEMENTS AS SHOWN HEREON ARE HEREBY DEDICATED TO THE MANORS AT BRUSH CREEK HOMEOWNERS' ASSOCIATION FOR THE PURPOSE OF CONSTRUCTING, MAINTAINING, REPAIRING, AND REPLACING A SUBDIVISION FENCE...

THE LANDSCAPE EASEMENTS ARE HEREBY ESTABLISHED AS PROTECTED AREAS FOR NATURAL VEGETATION, VEGETATIVE LANDSCAPING, AND IRRIGATION ONLY, STRUCTURES OF ANY KIND, WHETHER TEMPORARY OR PERMANENT ARE NOT PERMITTED WITHIN LANDSCAPE EASEMENTS...

THE ENTRANCE MONUMENT AREA AS SHOWN IN THE COMMON GROUND OF THIS PLAT IS HEREBY DEDICATED TO THE MANORS AT BRUSH CREEK HOMEOWNERS' ASSOCIATION FOR THE INSTALLATION AND MAINTENANCE OF SUBDIVISION SIGNS...

THE MANORS AT BRUSH CREEK HOMEOWNERS' ASSOCIATION SHALL BE OBLIGATED TO MAINTAIN, REPAIR, CONSTRUCT, IMPROVE AND OPERATE THE DETENTION BASIN, AS SHOWN ON THIS PLAT AND THE DETENTION FACILITIES, AND STORMWATER IMPROVEMENTS CONSTRUCTED THEREIN.

THE COMMON GROUND SHOWN ON THIS PLAT HAS BEEN CONVEYED FOREVER TO THE MANORS AT BRUSH CREEK HOMEOWNERS' ASSOCIATION, ITS SUCCESSORS AND ASSIGNS, BY GENERAL WARRANTY DEED RECORDED THE \_\_\_\_\_ DAY OF \_\_\_\_\_, 2022 IN DOCUMENT NO. \_\_\_\_\_ OF THE FRANKLIN COUNTY, MISSOURI RECORDS.

THIS SUBDIVISION IS SUBJECT TO COVENANTS, CONDITIONS AND RESTRICTIONS RECORDED IN THE MANORS AT BRUSH CREEK DECLARATION OF COVENANTS, CONDITIONS AND RESTRICTIONS FILED ON THE \_\_\_\_\_ DAY OF \_\_\_\_\_, 2022 IN DOCUMENT NO. \_\_\_\_\_ OF THE FRANKLIN COUNTY, MISSOURI RECORDS, OR AS AMENDED THEREAFTER.

BUILDING LINES AS SHOWN ON THIS PLAT ARE HEREBY ESTABLISHED.

IT IS HEREBY CERTIFIED THAT THERE ARE NO DELINQUENT TAXES OUTSTANDING.

IT IS HEREBY CERTIFIED THAT ALL EXISTING EASEMENTS ARE SHOWN OR NOTED ON THIS PLAT AS OF THE TIME AND DATE OF RECORDING OF THIS PLAT.

IN WITNESS WHEREOF, I HAVE HEREUNTO SET MY HAND THIS \_\_\_\_\_ DAY OF \_\_\_\_\_, 2022.

ELITE BRUSH CREEK DEVELOPMENT, LLC BY: ELITE DEVELOPMENT SERVICES II, LLC, SOLE MEMBER

BY: JEREMY ROTH, AUTHORIZED AGENT

STATE OF MISSOURI ) )SS. COUNTY OF \_\_\_\_\_ )

ON THIS \_\_\_\_\_ DAY OF \_\_\_\_\_, 2022, BEFORE ME PERSONALLY APPEARED JEREMY ROTH, TO ME PERSONALLY KNOWN, WHO, BEING BY ME DULY SWORN, DID SAY THAT HE IS THE DULY AUTHORIZED AGENT OF ELITE DEVELOPMENT SERVICES II, LLC, A MISSOURI LIMITED LIABILITY COMPANY AND SOLE MEMBER OF ELITE BRUSH CREEK DEVELOPMENT, LLC, A MISSOURI LIMITED LIABILITY COMPANY...

IN TESTIMONY WHEREOF, I HAVE HEREUNTO SET MY HAND AND AFFIXED MY OFFICIAL SEAL IN THE COUNTY AND STATE AFORESAID, THE DAY AND YEAR FIRST ABOVE WRITTEN.

MY COMMISSION EXPIRES: \_\_\_\_\_

NOTARY PUBLIC

CITY CERTIFICATION:

I, KIMBERLY BARFIELD, CITY CLERK FOR AND WITHIN THE CITY OF PACIFIC, MISSOURI, DO HEREBY CERTIFY THAT THE ABOVE PLAT OF "THE MANORS AT BRUSH CREEK" WAS APPROVED BY THE BOARD OF ALDERMEN OF THE CITY OF PACIFIC, MISSOURI BY ORDINANCE NO. \_\_\_\_\_ PASSED AND APPROVED THE \_\_\_\_\_ DAY OF \_\_\_\_\_, 2022.

NOW THEREFORE, THE CITY OF PACIFIC, MISSOURI, HAVING RIGHTS TO SEVERAL PERMANENT SIDEWALK EASEMENTS GRANTED BY INSTRUMENT RECORDED IN DEED BOOK 1459, PAGES 117-122 OF THE FRANKLIN COUNTY, MISSOURI RECORDS, AND HAVING RIGHTS TO SEVERAL PERMANENT DRAINAGE EASEMENTS GRANTED BY INSTRUMENT RECORDED IN DEED BOOK 1459, PAGES 111-116 OF THE FRANKLIN COUNTY, MISSOURI RECORDS, DOES HEREBY FOREVER REMISE, RELEASE, AND VACATE ALL RIGHTS TO SAID EASEMENTS AS SHOWN AND NOTED ON SHEET 1 OF THIS PLAT.

IN TESTIMONY WHEREOF, I HAVE HEREUNTO SET MY HAND AND AFFIXED MY OFFICIAL SEAL OF THE CITY OF PACIFIC, MISSOURI THIS \_\_\_\_\_ DAY OF \_\_\_\_\_, 2022.

KIMBERLY BARFIELD CITY CLERK, CITY OF PACIFIC, MISSOURI

COUNTY COLLECTOR'S CERTIFICATION:

I, DOUG TRENTMANN, COLLECTOR OF REVENUE FOR FRANKLIN COUNTY, MISSOURI, FIRST BEING SWORN DEPOSE AND SAY THAT I AM FAMILIAR WITH THE LAND SHOWN AND DESCRIBED IN THIS PLAT AND FURTHER STATE THAT THERE ARE NO DELINQUENT TAX ASSESSMENTS ON THE AFORESAID LAND SHOWN DUE FRANKLIN COUNTY.

DOUG TRENTMANN, COLLECTOR OF REVENUE FRANKLIN COUNTY, MISSOURI

THE STERLING CO. ENGINEERS & SURVEYORS 5055 New Baumgartner Road St. Louis, Missouri 63129 Ph. 314-487-0440 Fax 314-487-8944 www.sterling-eng-sur.com

Table with 3 columns: DRAWN BY, CHECKED BY, JOB NO.; and 3 rows: GFS, JAH, 19-12-425; MSD P# - N/A, DATE: JAN. 27, 2021, THE MANORS AT BRUSH CREEK

THE MANORS AT BRUSH CREEK

TWO TRACTS OF LAND BEING PART OF THE SOUTH HALF OF THE SOUTHWEST QUARTER IN SECTION 11, TOWNSHIP 43 NORTH, RANGE 2 EAST OF THE FIFTH PRINCIPAL MERIDIAN, CITY OF PACIFIC, FRANKLIN COUNTY, MISSOURI

ZONED "R-1B (PUD-PDR)" SINGLE FAMILY RESIDENTIAL WITH PLANNED UNIT DISTRICT - PLANNED DISTRICT RESIDENTIAL PER CITY OF PACIFIC, MISSOURI ORDINANCE NO. 3275

DEVELOPMENT OVERVIEW

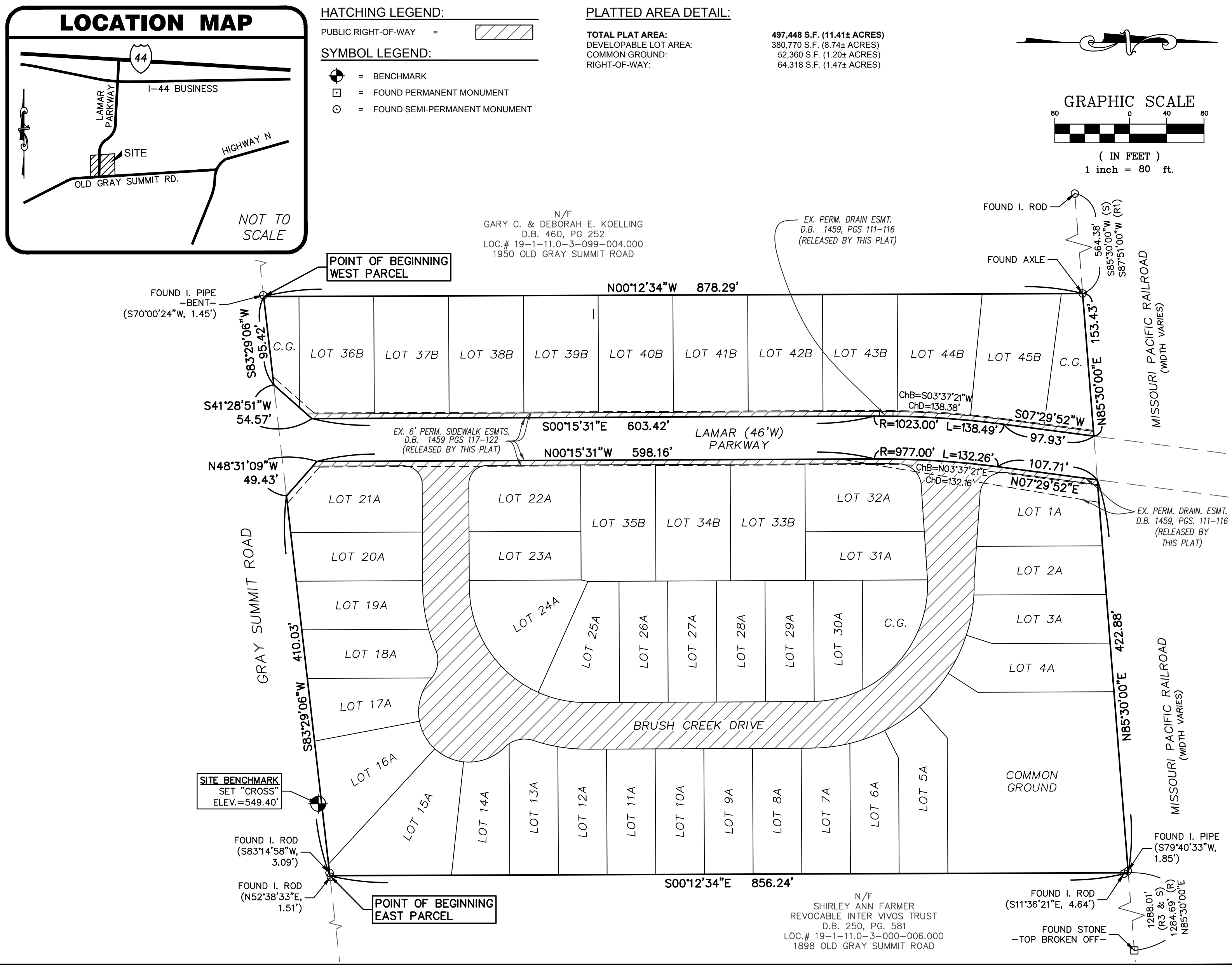

SURVEYOR'S NOTES

- 1. THE PROFESSIONAL WHOSE SIGNATURE AND PERSONAL SEAL APPEARS BELOW ASSUMES RESPONSIBILITY ONLY FOR WHAT APPEARS ON THIS PLAT AND DISCLAIMS... 2. THIS PLAT CONTAINS 497,448 SQUARE FEET (11.41 ACRES MORE OR LESS)... 3. THIS PLAT IS LOCATED WITHIN ZIP CODE 63069...

PROPERTY DESCRIPTION:

WEST PARCEL: A TRACT OF LAND BEING PART OF THE SOUTH HALF OF THE SOUTHWEST QUARTER IN SECTION 11, TOWNSHIP 43 NORTH, RANGE 2 EAST OF THE 5TH PRINCIPAL MERIDIAN, CITY OF PACIFIC, FRANKLIN COUNTY, MISSOURI, BEING MORE PARTICULARLY DESCRIBED AS FOLLOWS:

BEGINNING AT THE INTERSECTION OF THE NORTH RIGHT-OF-WAY LINE OF GRAY SUMMIT ROAD AND THE EAST LINE OF PROPERTY NOW OR FORMERLY TO GARY C. AND DEBORAH E. KOELLING, AS RECORDED IN DEED BOOK 460, PAGE 252 OF THE FRANKLIN COUNTY RECORDS, WHERE A FOUND IRON PIPE BEARS SOUTH 70°00'24" WEST, 1.45 FEET; THENCE LEAVING SAID CORNER ALONG SAID EAST LINE NORTH 0°12'34" WEST, 878.29 FEET TO THE INTERSECTION OF SAID EAST LINE AND THE SOUTH RIGHT-OF-WAY LINE OF MISSOURI PACIFIC RAILROAD, WHERE AN AXLE WAS FOUND; THENCE ALONG SAID SOUTH RIGHT-OF-WAY LINE NORTH 85°30'00" EAST, 153.43 FEET TO THE INTERSECTION OF SAID SOUTH RIGHT-OF-WAY LINE AND THE WEST RIGHT-OF-WAY LINE OF LAMAR PARKWAY; THENCE ALONG SAID WEST RIGHT-OF-WAY LINE THE FOLLOWING COURSES, DISTANCE AND CURVES: SOUTH 7°29'52" WEST, 97.93 FEET TO A POINT OF CURVATURE; THENCE ALONG A CURVE TO THE LEFT HAVING A RADIUS OF 1,023.00 FEET, WHOSE CHORD BEARS SOUTH 3°37'21" WEST, 138.38 FEET, AND ARC DISTANCE OF 138.49 FEET TO A POINT OF TANGENCY; THENCE SOUTH 0°15'31" EAST, 603.42 FEET TO A POINT OF NON-TANGENCY; THENCE SOUTH 41°28'51" WEST, 54.57 FEET TO A POINT OF NON-TANGENCY ON THE NORTH RIGHT-OF-WAY LINE OF SAID GRAY SUMMIT ROAD; THENCE SOUTH 83°29'06" WEST, 95.42 FEET TO THE POINT OF BEGINNING AND CONTAINS 115,864 SQUARE FEET OR 2.66 ACRES, MORE OR LESS ACCORDING TO A SURVEY PERFORMED BY THE STERLING COMPANY DURING THE MONTH OF JUNE, 2021 UNDER ORDER NUMBER 19-12-425.

EAST PARCEL: A TRACT OF LAND BEING PART OF THE SOUTH HALF OF THE SOUTHWEST QUARTER IN SECTION 11, TOWNSHIP 43 NORTH, RANGE 2 EAST OF THE 5TH PRINCIPAL MERIDIAN, CITY OF PACIFIC, FRANKLIN COUNTY, MISSOURI, BEING MORE PARTICULARLY DESCRIBED AS FOLLOWS:

BEGINNING AT THE INTERSECTION OF THE NORTH RIGHT-OF-WAY LINE OF GRAY SUMMIT ROAD AND THE WEST LINE OF PROPERTY NOW OR FORMERLY TO SHIRLEY ANN FARMER, TRUSTEE OF THE SHIRLEY ANN FARMER REVOCABLE INTER VIVOS TRUST DATED AUGUST 30, 2006, AS RECORDED IN DOCUMENT NUMBER 1809467 OF SAID FRANKLIN COUNTY RECORDS, WHERE A FOUND IRON ROD BEARS NORTH 52°38'33" EAST, 1.51 FEET AND ALSO WHERE A FOUND IRON ROD BEARS SOUTH 83°14'58" WEST, 3.09 FEET; THENCE LEAVING SAID CORNER ALONG THE NORTH RIGHT-OF-WAY LINE OF SAID GRAY SUMMIT ROAD, SOUTH 83°29'06" WEST, 410.03 FEET TO A POINT OF NON-TANGENCY AT THE INTERSECTION OF THE NORTH RIGHT-OF-WAY LINE OF GRAY SUMMIT ROAD AND THE EAST RIGHT-OF-WAY LINE OF LAMAR (46' WIDE) PARKWAY; THENCE LEAVING SAID POINT ALONG SAID EAST LINE THE FOLLOWING COURSES, DISTANCES AND CURVES: NORTH 48°31'09" WEST, 49.43 FEET TO A POINT OF NON-TANGENCY; THENCE NORTH 0°15'31" EAST, 598.16 FEET TO A POINT OF CURVATURE; THENCE ALONG A CURVE TO THE RIGHT HAVING A RADIUS OF 977.00 FEET, WHOSE CHORD BEARS NORTH 3°37'21" EAST, 132.16 FEET, AN ARC DISTANCE OF 132.26 FEET TO A POINT OF TANGENCY; THENCE NORTH 7°29'52" EAST, 107.71 FEET TO A POINT OF NON-TANGENCY ON THE SOUTH RIGHT-OF-WAY LINE OF MISSOURI PACIFIC RAILROAD; THENCE ALONG SAID SOUTH LINE, NORTH 85°30'00" EAST, 422.88 FEET TO THE NORTHWEST CORNER OF ABOVE-MENTIONED FARMER PROPERTY, WHERE A FOUND IRON PIPE BEARS SOUTH 79°40'33" WEST, 1.85 FEET AND A FOUND IRON ROD WITH CAP BEARS SOUTH 11°36'21" EAST 4.64 FEET; THENCE ALONG SAID WEST LINE, SOUTH 0°12'34" EAST, 856.24 FEET TO THE POINT OF BEGINNING AND CONTAINS 381,584 SQUARE FEET OR 8.75 ACRES, MORE OR LESS ACCORDING TO A SURVEY PERFORMED BY THE STERLING COMPANY DURING THE MONTH OF JUNE, 2021 UNDER ORDER NUMBER 19-12-425.

THE ABOVE TWO PARCELS CONTAIN A COMBINED AREA OF 497,448 SQUARE FEET, OR 11.41 ACRES, MORE OR LESS.

BENCHMARKS:

THE STERLING COMPANY HAS ESTABLISHED A SITE BENCHMARK, AS SHOWN HEREON AND DESCRIBED HEREON. THE SITE DATUM HAS BEEN ESTABLISHED VIA A GPS REAL-TIME KINEMATIC NETWORK PUBLISHED AND MAINTAINED BY THE MISSOURI DEPARTMENT OF TRANSPORTATION (MODOOT RTK) USING PUBLISHED BASE STATION "MOSF" AND OBSERVING THE SITE BENCHMARK.

SITE BENCHMARK: ELEVATION = 549.40' (NAVD 88)

"CROSS" ON THE NORTHERN EDGE OF CONCRETE SIDEWALK ALONG GRAY SUMMIT ROAD, 332.0 FEET EAST OF THE INTERSECTION OF THE RIGHT-OF-WAY OF GRAY SUMMIT ROAD AND LAMAR PARKWAY, 0.2 FEET SOUTH OF THE NORTHERN EDGE OF SAID SIDEWALK, 8.4 FEET EAST OF A FIRE HYDRANT, AND 150.2 FEET WEST OF A CURB INLET, AS SHOWN HEREON.

SURVEYOR'S CERTIFICATION

ORDER NUMBER: 19-12-425 THE STERLING COMPANY 5055 NEW BAUMGARTNER ROAD ST. LOUIS, MISSOURI 63129 PHONE: (314) 487-0440

THIS IS TO CERTIFY TO ELITE BRUSH CREEK DEVELOPMENT, LLC THAT WE HAVE, DURING THE MONTH OF JUNE, 2021, PERFORMED A BOUNDARY SURVEY OF TWO TRACTS OF LAND BEING PART OF THE SOUTH HALF OF THE SOUTHWEST QUARTER IN SECTION 11, TOWNSHIP 43 NORTH, RANGE 2 EAST OF THE FIFTH PRINCIPAL MERIDIAN, CITY OF PACIFIC, FRANKLIN COUNTY, MISSOURI; AND BASED UPON SAID SURVEY HAVE SUBDIVIDED SAID TRACT OF LAND IN THE MANNER SHOWN HEREON. THIS PLAT AND THE SURVEY ON WHICH IT IS BASED MEETS OR EXCEEDS THE "MISSOURI STANDARDS FOR PROPERTY BOUNDARY SURVEYS" AS AN "URBAN" CLASS PROPERTY IN EFFECT AT THE DATE OF THIS PLAT.

THE STERLING COMPANY MO. REG. 307-D

JAMEY A. HENSON, P.L.S., VICE PRESIDENT DATE MO. REG. L.S. #2007017963

Vertical text on the left edge of the page, likely a drawing name or file path.



# THE MANORS AT BRUSH CREEK

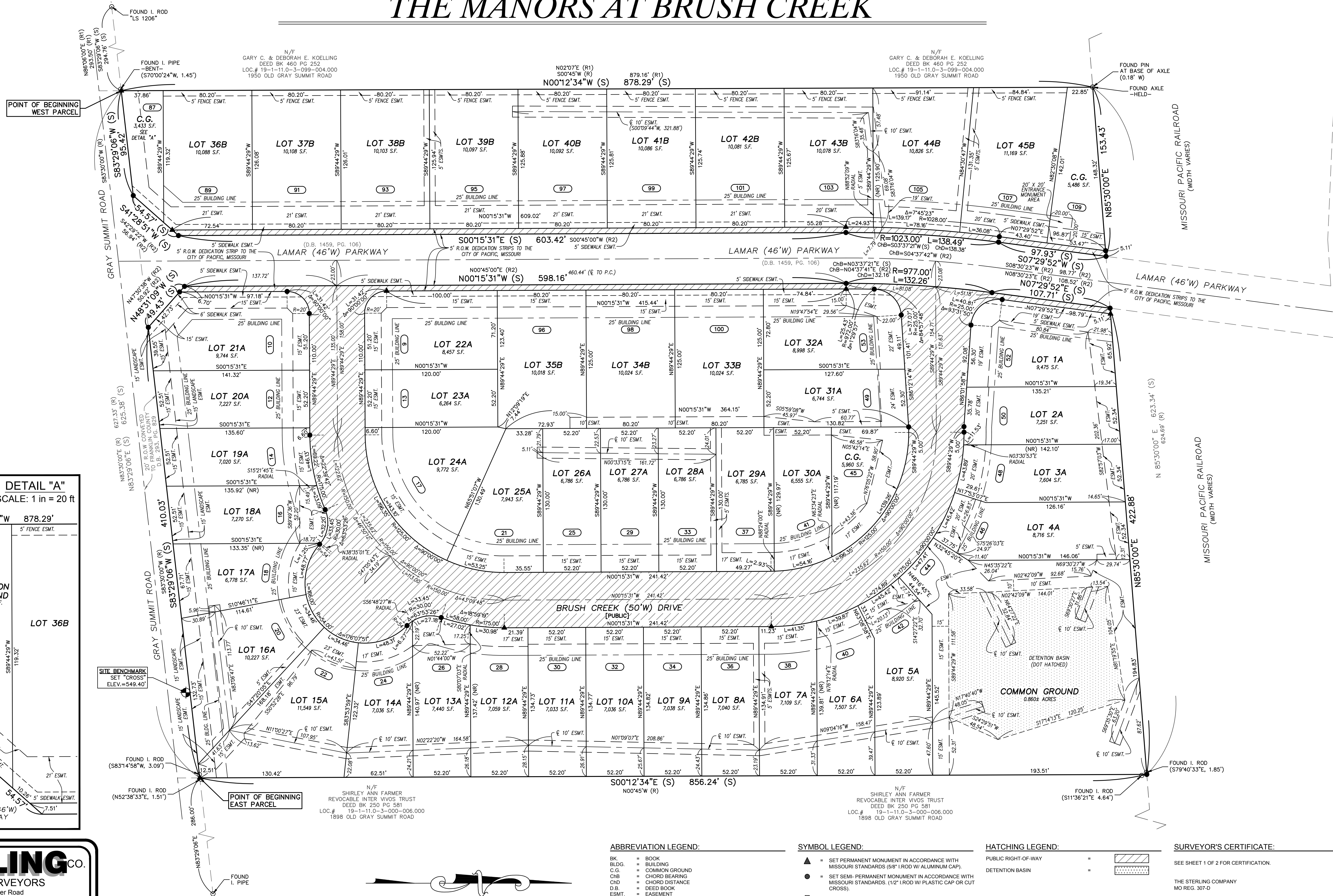

**DETAIL "A"**  
SCALE: 1 in = 20 ft

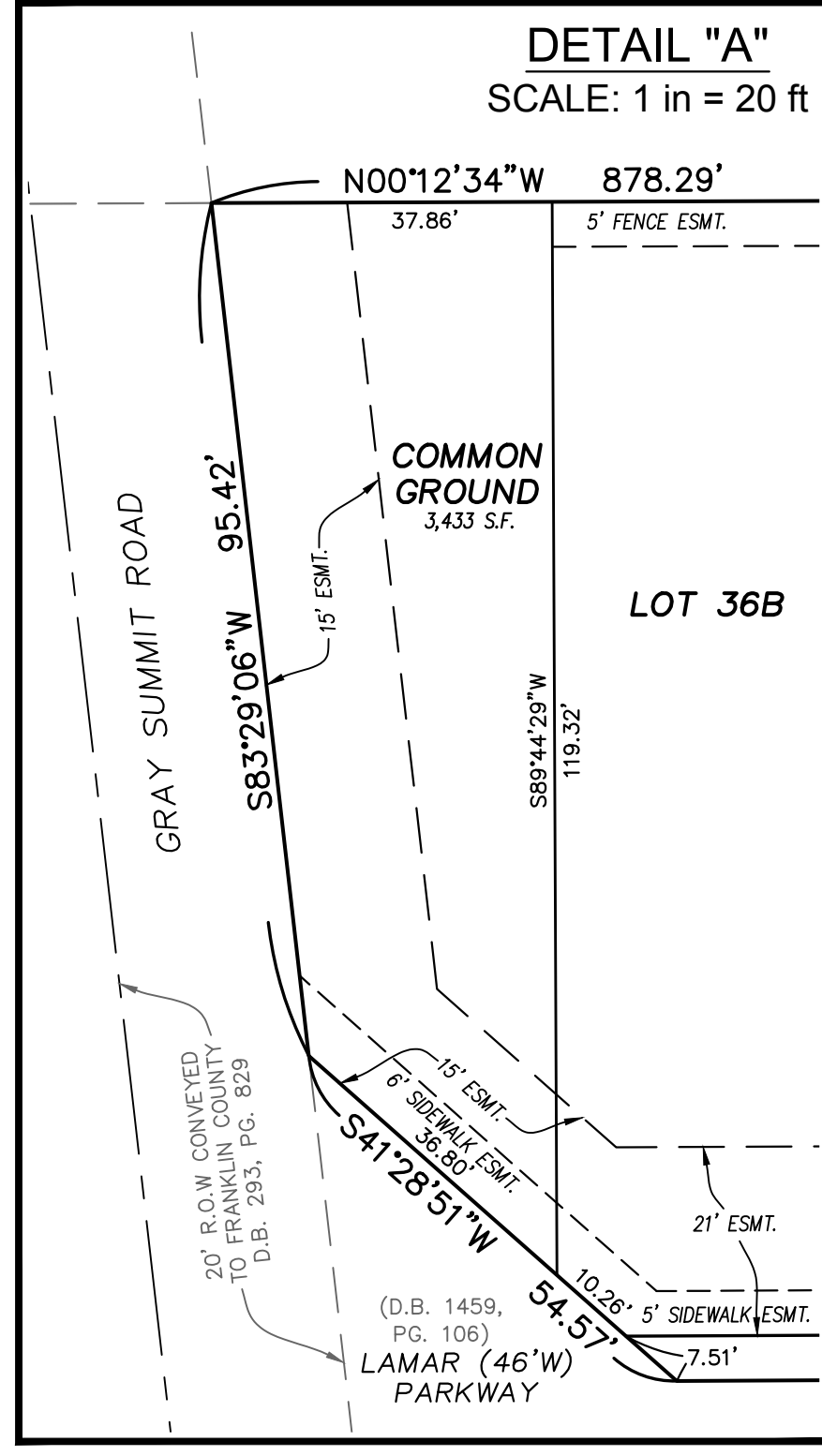

**THE STERLING CO.**  
ENGINEERS & SURVEYORS  
5055 New Baumgartner Road  
St. Louis, Missouri 63129  
Ph. 314-487-0440 Fax 314-487-8944  
www.sterling-eng-sur.com

<b>DRAWN BY:</b>	GFS	MSD P# - N/A
<b>CHECKED BY:</b>	JAH	DATE: JAN. 27, 2021
<b>JOB NO.:</b>	19-12-425	THE MANORS AT BRUSH CREEK

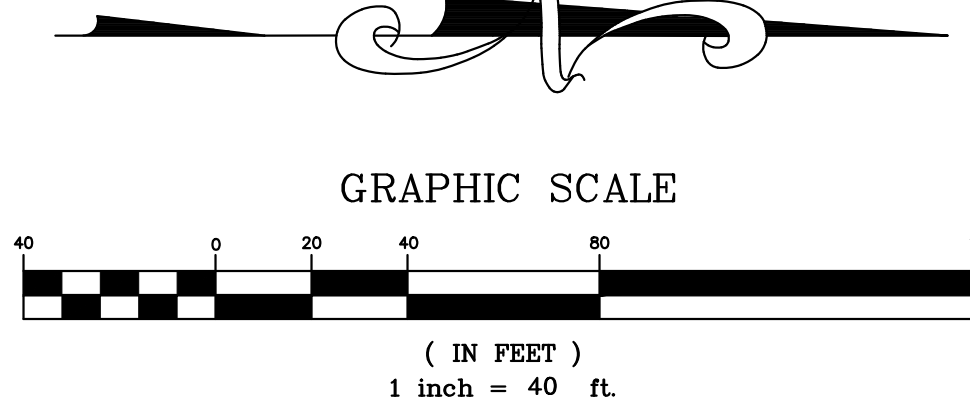

**ABBREVIATION LEGEND:**

- BK. = BOOK
- BLDG. = BUILDING
- C.G. = COMMON GROUND
- CHB = CHORD BEARING
- CHD = CHORD DISTANCE
- D.B. = DEED BOOK
- ESMT. = EASEMENT
- FND. = FOUND
- N/F = NOW OR FORMERLY
- (NR) = NON-RADIAL
- P.B. = PLAT BOOK
- P.O.B. = POINT OF BEGINNING
- P.O.C. = POINT OF COMMENCEMENT
- P.V.M.T. = PAVEMENT
- (R) = RECORD
- R.O.W. = RIGHT-OF-WAY
- RET. = RETAINING
- (S) = SURVEYED
- S.F. = SQUARE FEET
- T.S.C.L. = TEMPORARY SLOPE AND CONSTRUCTION LICENSE
- W. = WIDTH

**SYMBOL LEGEND:**

- ▲ = SET PERMANENT MONUMENT IN ACCORDANCE WITH MISSOURI STANDARDS (5/8" ROD W/ ALUMINUM CAP).
- = SET SEMI-PERMANENT MONUMENT IN ACCORDANCE WITH MISSOURI STANDARDS (1/2" IROD W/ PLASTIC CAP OR CUT CROSS).
- = FOUND PERMANENT MONUMENT
- = FOUND SEMI-PERMANENT MONUMENT
- ⊕ = FOUND CROSS
- ⊙ = FOUND ANCHOR
- ⊕ = BENCHMARK
- 523 = ADDRESS

**HATCHING LEGEND:**

- PUBLIC RIGHT-OF-WAY
- DETENTION BASIN

**SURVEYOR'S CERTIFICATE:**

SEE SHEET 1 OF 2 FOR CERTIFICATION.  
THE STERLING COMPANY  
MO REG. 307-D